

# FINGER LAKES REGION AGING SERVICES DEMAND MODEL

## FINGER LAKES REGION ESTIMATE

Projected to 2025 with 2007 Base Year

6/28/2010 15:00

Adult Day Care

Senior Care Work Force Dashboard

### Environmental

**Net Annual % Change in 65+ Use Rates** 0.00%

**Finger Lakes Use Rate** Current 297 → 2025 291

**% Change in Acute Care Transfer % to SNF** +0%  
Current = 17% → 2025 = 17%

**Annual Change in Short Stay Length of Stay SNF** 0.00%

**Impact of Changes in Available Caregivers** 25%  
% of "At Risk" 85+ Utilizing Formal Services

Market Rate  
Affordable-Funded  
Affordable-Unfunded

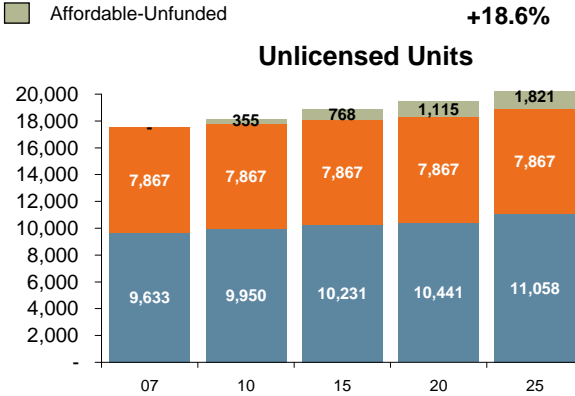

### Public Funding

**Net Increase in "Real" Annual HCBS Funding Dollars** + \$6.1M

60% AL Substitution - 40% Other HCBS

**User Defined Annual HCBS Funding (per Capita 85+)** (in Current Dollars)

Current \$4,690 → Proposed \$4,638 -1.1%

**Assumed State Savings - NH** 25%

Short Stay  
Long Stay  
Total Beds 52  
Beds / 1,000 65+ 30  
Current Supply

### Nursing Facility Beds-20.8%

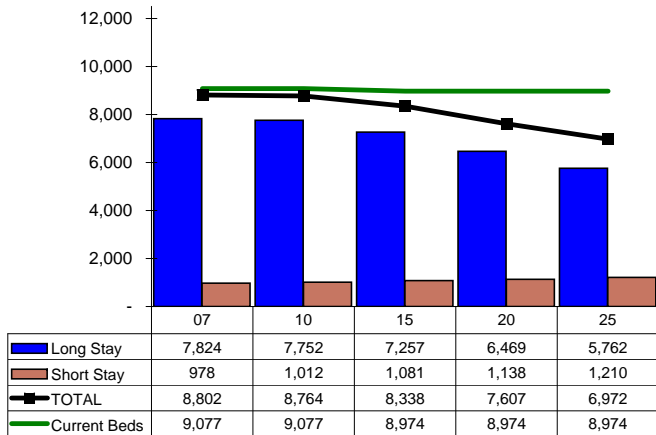

### Licensed Units (ALP/ACF)

+35.6%

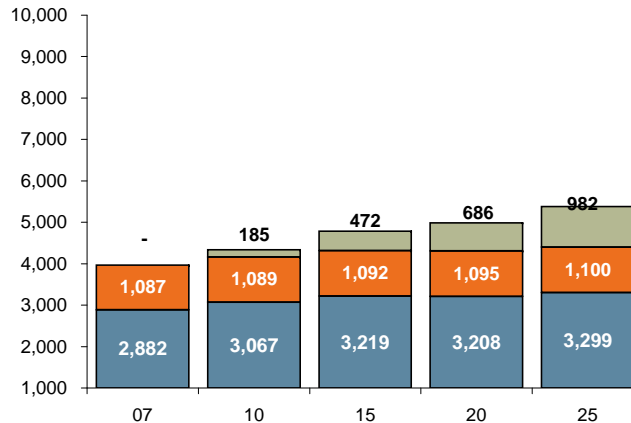

### Home Care Visits

(Thousands) +48.2%

County Funded HH 35.4%  
County Funded-Other 150.2%  
Medicare 30.1%

Year	County Funded-Other	Medicare	County Funded HH
07	541	748	2,558
10	645	739	2,612
15	870	248	2,752
20	1,100	270	2,965
25	1,354	292	3,281

### Lifestyle/Choice

**Substitution of Housing/Service Alternatives for NF Care** User 37.5%

### Income & Wealth

**Percentage Change of >65+ Dual Eligible by 2025 (vs. Current)** 0.0%

65+ Dual Eligible % Current 20.9% → 2025 20.9%

**Population 65+ CAGR = 1.4% (+38%)**

**Population 85+ CAGR = 0.3% (+6%)**

CAGR = Compound Annual Growth Rate

Version 3.0

# FINGER LAKES REGION AGING SERVICES FUNDING MODEL MODEL

## FINGER LAKES REGION ESTIMATE

Projected to 2025 with 2007 Base Year

### Public Funding

Net Increase in "Real" Annual HCBS Funding Dollars + \$6.1M



**60% AL Substitution - 40% Other HCBS**

User Defined Annual HCBS Funding (per Capita 85+)  
(in Current Dollars)

Current **\$4,690** ➔ Proposed **\$4,638 -1.1%**

Assumed State Savings - NH 25%

### Income & Wealth

Percentage Change of >65+ Dual Eligible by 2025 (vs. Current) 0.0%

65+ Dual Eligible % 20.9%

### Lifestyle/Choice

Substitution of Housing/Service Alternatives for NF Care User 37.5%

Medicaid COLA = 0.0%

\*Includes funding for licensed units.

6/28/2010 15:00

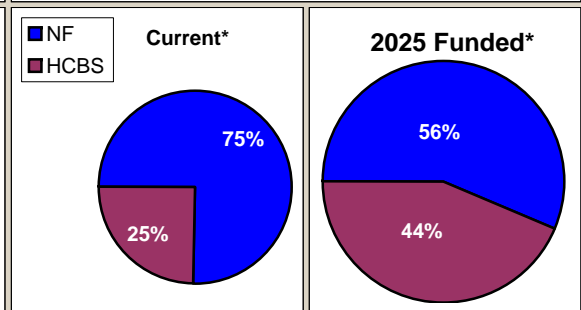
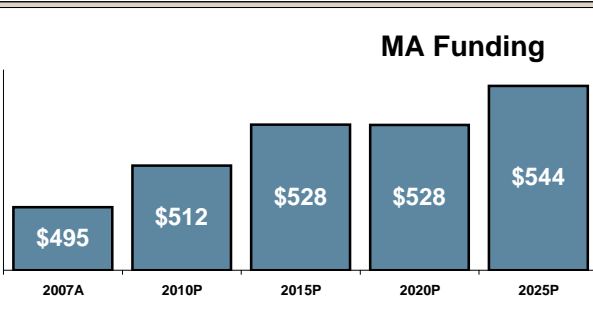
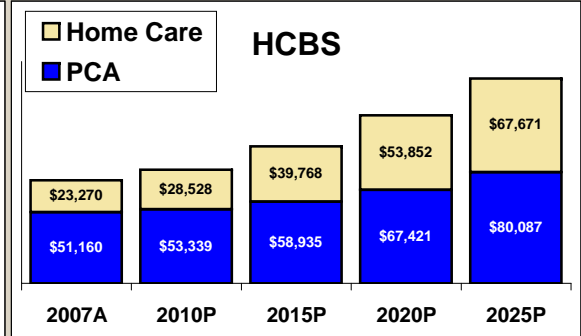
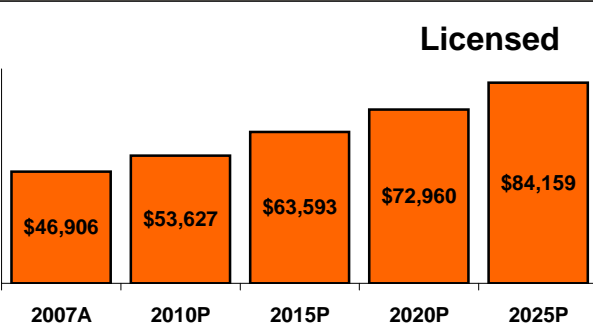
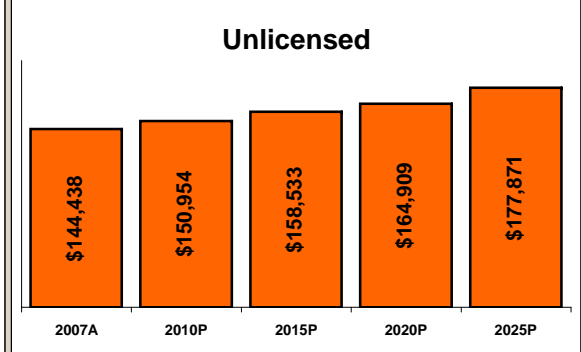
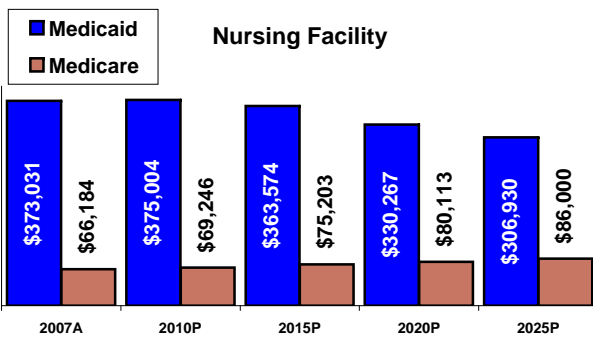

Spending Per Capita 65+ Current \$2,910 ➔ \$2,314 in 2025

# Funding Inputs

Finger Lakes Region

Medicaid Inflation 0.00%  
 Medicare Inflation 0.00%

## % of Average Rate for Low Acuity

2015	2020	2025
75%	85%	85%

Percentage savings of former NF resident in AL 0%

Unlicensed Monthly Funding \$ 1,530 Linked to model inputs

		<u>Weight</u>	<u>AL</u>
Yates County	1,530	1.00	43,152
Wayne County	1,530	1.00	43,152
Steuben County	1,194	0.78	33,673
Seneca County	1,530	1.00	43,152
Schuyler County	567	0.37	15,994
Ontario County	1,346	0.88	37,951
Monroe County	1,458	0.95	41,118
Livingston County	1,464	0.96	41,285
Chemung County	1,169	0.76	32,982
State Wide	1,530		43,152

Adult Day Care % savings of Low Acuity NF rate used 0%

ADC Days With MA Funding 10%

### Substitution Metrics (Increment \$\$ Only)

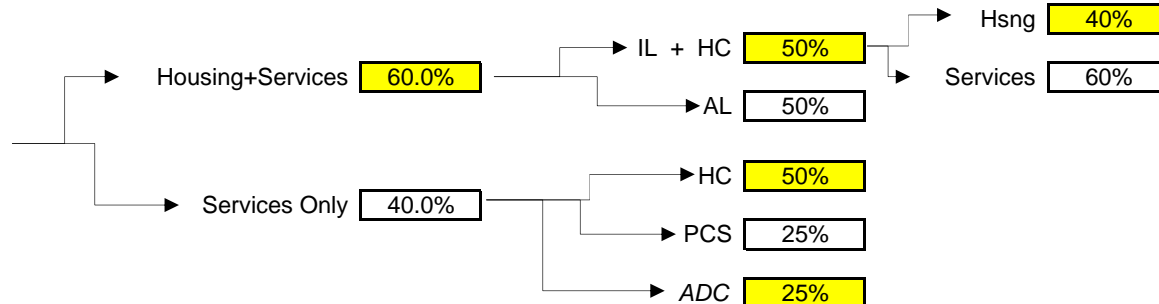

#### % of Substitution Attributed...

AL	30.0%	Per above metric	30.0%	Per above metric
IL (Housing)	12.0%	Per above metric	12.0%	Per above metric
Adult Day Care	10.0%	Per above metric	10.0%	Per above metric
HCBS Home Care (Services)	48.0%	Per above metric	48.0%	Per above metric

### HCBS Funding Metrics (Increment \$\$ Only)

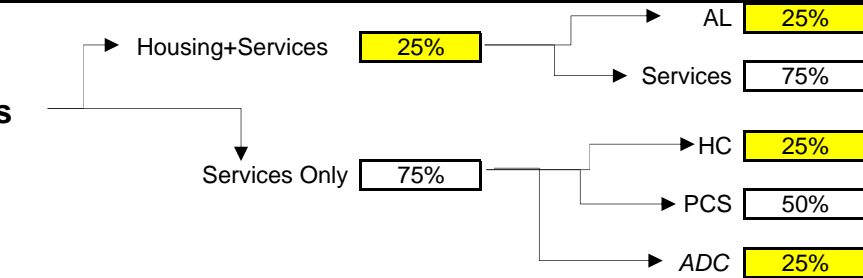

#### % of Future HCBS \$\$ to...

Home Care	37.5%	see above HCBS funding matrix
Personal Care	37.5%	see above HCBS funding matrix
Assisted Living (Housing Component)	6.25%	see above HCBS funding matrix
Adult Day Care	18.75%	

### Caregiver Impacts

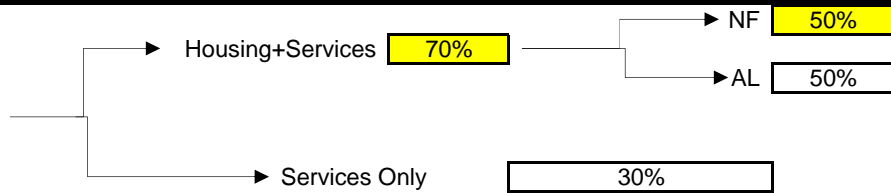

#### % of Future HCBS \$\$ to...

AL	35%	see above HCBS funding matrix
NF	35%	see above HCBS funding matrix
HCBS Home Care (Services)	30%	see above HCBS funding matrix

**NURSING FACILITY MEDICARE FUNDING**

**\$ in (000s)**

**FINGER LAKES REGION ESTIMATE**

	2010	2015	2020	2025
Base Year 2007	\$ 66,184	\$ 66,184	\$ 66,184	\$ 66,184
Adjustment to Regional Use Rate Funding	-	-	-	-
<b>ADJUSTED BASE YEAR</b>	<b>66,184</b>	<b>66,184</b>	<b>66,184</b>	<b>66,184</b>
<b>Cumulative Projected Funding Impact of Population Change</b>				
Net Change in Funding Due to Population	3,062	9,019	13,928	19,815
<b>Projected Funding (Constant Use Rates)</b> <small>(per Age Cohort)</small>	<b>69,246</b>	<b>75,203</b>	<b>80,113</b>	<b>86,000</b>
<b>Cumulative Projected Funding Impact of Key Demand Influencers</b>				
Net Change in Hospital Use / Transfer Rates / Short Stay Length of Stay	-	-	-	-
Impact of Changes in Wealth/Income (At Risk)	-	-	-	-
Impact of Entitlement Program Funding for Home & Community Alternatives	-	-	-	-
Impact of Changes in Family/Community Caregiving	-	-	-	-
Substitution of Alternative Housing/Service Alternatives for Former NH Residents	-	-	-	-
<b>Projected Impact of Demand Influencers</b>	<b>-</b>	<b>-</b>	<b>-</b>	<b>-</b>
<b>PROJECTED FUNDING</b>	<b>\$ 69,246</b>	<b>\$ 75,203</b>	<b>\$ 80,113</b>	<b>\$ 86,000</b>
% Change vs. Base Year	4.6%	13.6%	21.0%	29.9%
<i>CAGR % Change during Periods</i>	1.5%	1.7%	1.3%	1.4%

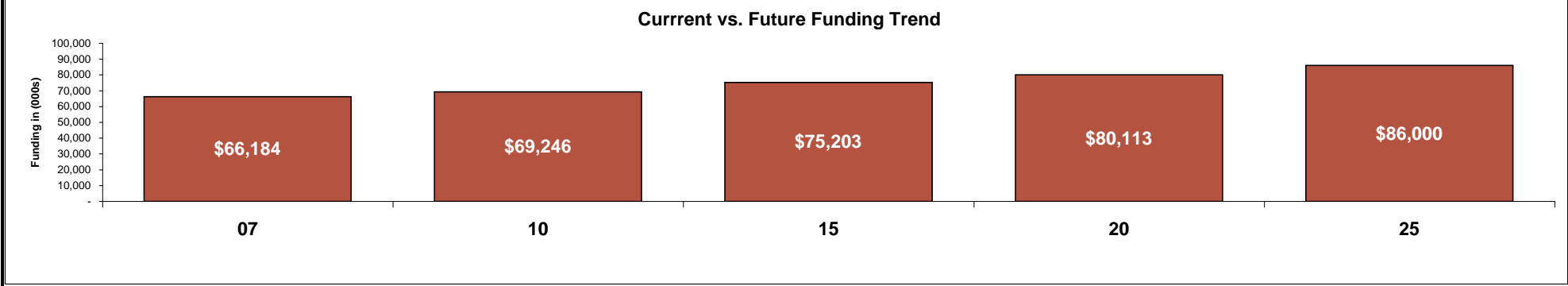
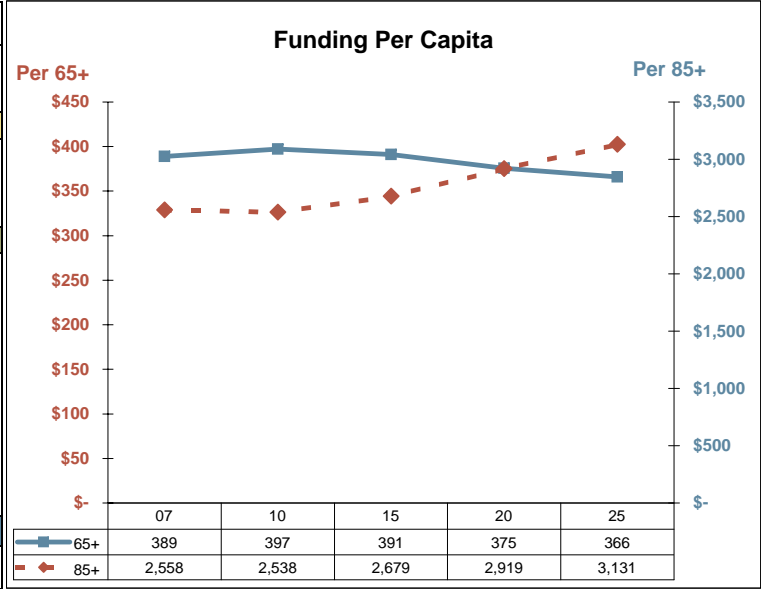

**NURSING FACILITY MEDICAID FUNDING**

**\$ in (000s)**

**FINGER LAKES REGION ESTIMATE**

	2010	2015	2020	2025
Base Year 2007	\$ 373,031	\$ 373,031	\$ 373,031	\$ 373,031
Adjustment to Regional Use Rate Funding	-	-	-	-
<b>ADJUSTED BASE YEAR</b>	<b>373,031</b>	<b>373,031</b>	<b>373,031</b>	<b>373,031</b>
<b>Cumulative Projected Funding Impact of Population Change</b>				
Net Change in Funding Due to Population	16,324	30,928	31,536	39,325
<b>Projected Funding (Constant Use Rates)</b> <small>(per Age Cohort)</small>	<b>389,355</b>	<b>403,960</b>	<b>404,568</b>	<b>412,357</b>
<b>Cumulative Projected Funding Impact of Key Demand Influencers</b>				
Net Change in Hospital Use / Transfer Rates / Short Stay Length of Stay	-	-	-	-
Impact of Changes in Wealth/Income (At Risk)	-	-	-	-
Impact of Entitlement Program Funding for Home & Community Alternatives	(809)	(2,158)	(3,095)	(4,285)
Impact of Changes in Family/Community Caregiving	616	2,752	4,516	8,237
Substitution of Alternative Housing/Service Alternatives for Former NH Residents	(14,158)	(40,979)	(75,722)	(109,378)
<b>Projected Impact of Demand Influencers</b>	<b>(14,351)</b>	<b>(40,386)</b>	<b>(74,301)</b>	<b>(105,427)</b>
<b>PROJECTED FUNDING</b>	<b>\$ 375,004</b>	<b>\$ 363,574</b>	<b>\$ 330,267</b>	<b>\$ 306,930</b>
% Change vs. Base Year	0.5%	-2.5%	-11.5%	-17.7%
CAGR % Change during Periods	0.2%	-0.6%	-1.9%	-1.5%

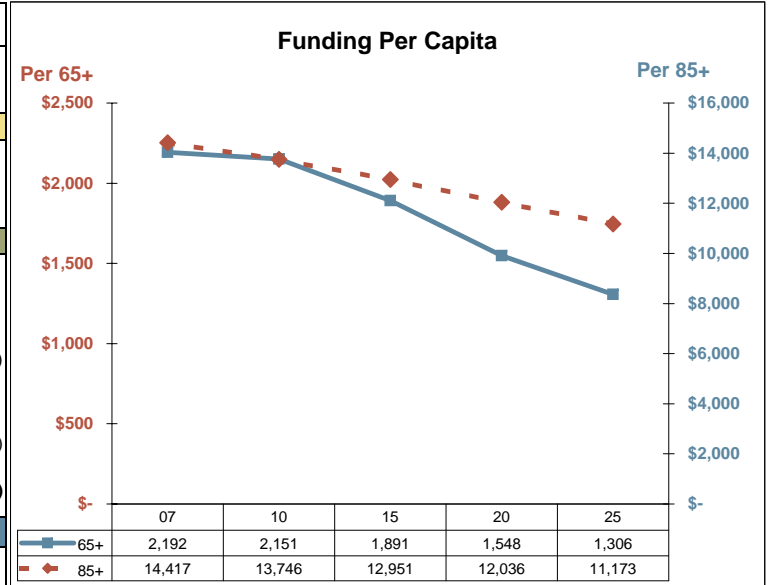

**Current vs. Future Funding Trend**

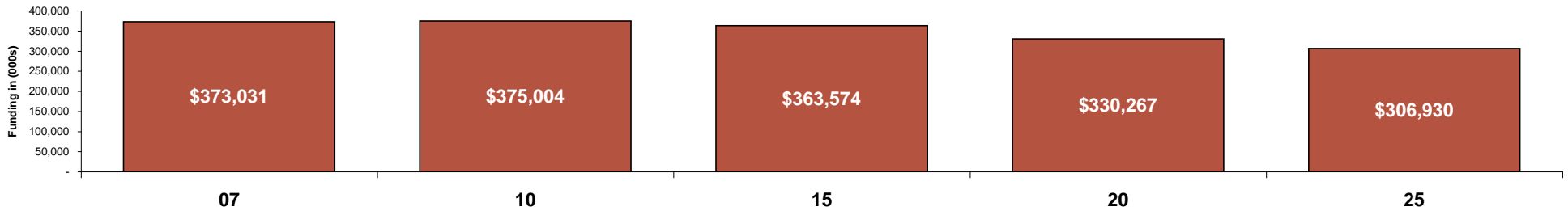

## NURSING FACILITY BED NEED

	2010	2015	2020	2025
Base Year 2007	8,802	8,802	8,802	8,802
Adjustment to Regional Use Rate	-	-	-	-
<b>ADJUSTED BASE YEAR</b>	<b>8,802</b>	<b>8,802</b>	<b>8,802</b>	<b>8,802</b>
<b>Cumulative Projected Impact of Population Change</b>				
Net Change in Population	417	824	890	1,136
<b>Projected Demand (Constant Use Rates)</b> <small>(per Age Cohort)</small>	<b>9,219</b>	<b>9,626</b>	<b>9,693</b>	<b>9,939</b>
<b>Cumulative Projected Impact of Key Demand Influencers</b>				
Net Change in Hospital Use / Transfer Rates / Short Stay Length of Stay	-	-	-	-
Impact of Changes in Wealth/Income (At Risk)	-	-	-	-
Impact of Entitlement Program Funding for Home & Community Alternatives	(25)	(68)	(97)	(134)
Impact of Changes in Family/Community Caregiving	14	65	106	194
Substitution of Alternative Housing/Service Alternatives for Former NH Residents	(444)	(1,285)	(2,095)	(3,026)
<b>Projected Impact of Demand Influencers</b>	<b>(455)</b>	<b>(1,288)</b>	<b>(2,086)</b>	<b>(2,967)</b>
<b>PROJECTED DEMAND</b>	<b>8,764</b>	<b>8,338</b>	<b>7,607</b>	<b>6,972</b>
% Change vs. Base Year	-0.4%	-5.3%	-13.6%	-20.8%
<i>CAGR % Change during Periods</i>	-0.1%	-1.0%	-1.8%	-1.7%

## FINGER LAKES REGION ESTIMATE

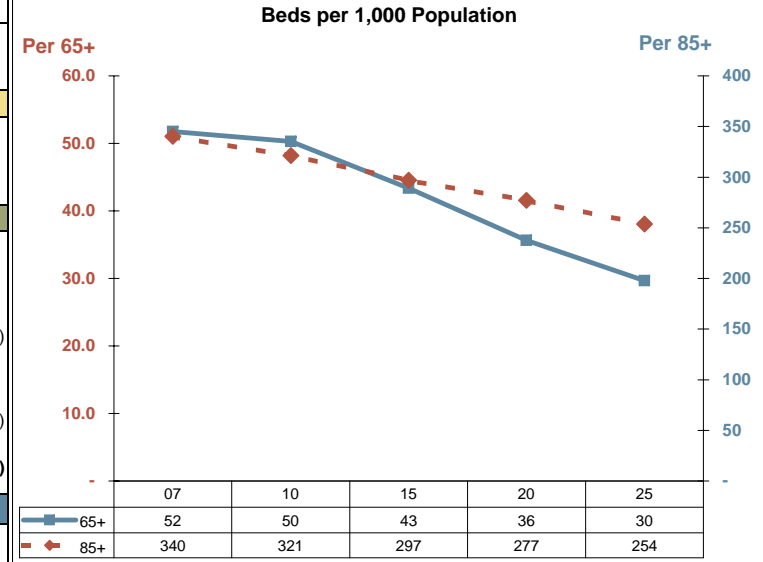

### Current vs. Future Bed Need Trends

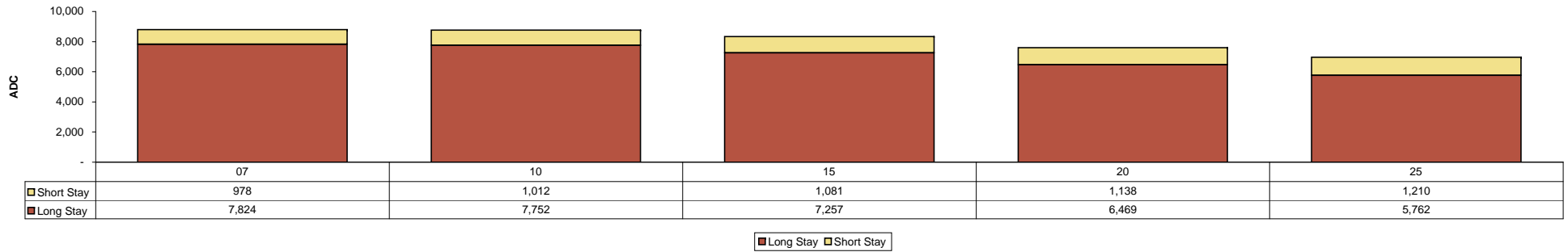

Licensed Funding - ALP/ACF		\$ in (000s)			FINGER LAKES REGION ESTIMATE	
	2010	2015	2020	2025		
Base Year 2007	\$ 46,906	\$ 46,906	\$ 46,906	\$ 46,906		
Adjustment to Regional Use Rate	-	-	-	-		
<b>ADJUSTED BASE YEAR</b>	<b>46,906</b>	<b>46,906</b>	<b>46,906</b>	<b>46,906</b>		
<b>Cumulative Projected Impact of Population Change</b>						
Net Change in Population	2,546	3,970	2,848	2,891		
<b>Projected Demand (Constant Use Rates)</b> <i>(per Age Cohort)</i>	<b>49,452</b>	<b>50,876</b>	<b>49,754</b>	<b>49,797</b>		
<b>Cumulative Projected Impact of Key Demand Influencers</b>						
Net Change in Hospital Use / Transfer Rates	-	-	-	-		
Impact of Changes in Wealth/Income (At Risk)	-	-	-	-		
Impact of Entitlement Program Funding for Home & Community Alternatives	-	-	-	-		
Impact of Changes in Family/Community Caregiving	302	1,424	2,330	4,229		
Substitution of Alternative Housing/Service Alternatives for Former NH Residents	3,873	11,292	20,875	30,132		
<b>Projected Impact of Demand Influencers</b>	<b>4,175</b>	<b>12,716</b>	<b>23,205</b>	<b>34,361</b>		
<b>PROJECTED DEMAND</b>	<b>\$ 53,627</b>	<b>\$ 63,593</b>	<b>\$ 72,960</b>	<b>\$ 84,159</b>		
% Change vs. Base Year	14.3%	35.6%	55.5%	79.4%		
<i>CAGR % Change during Periods</i>	<i>4.6%</i>	<i>3.5%</i>	<i>2.8%</i>	<i>2.9%</i>		

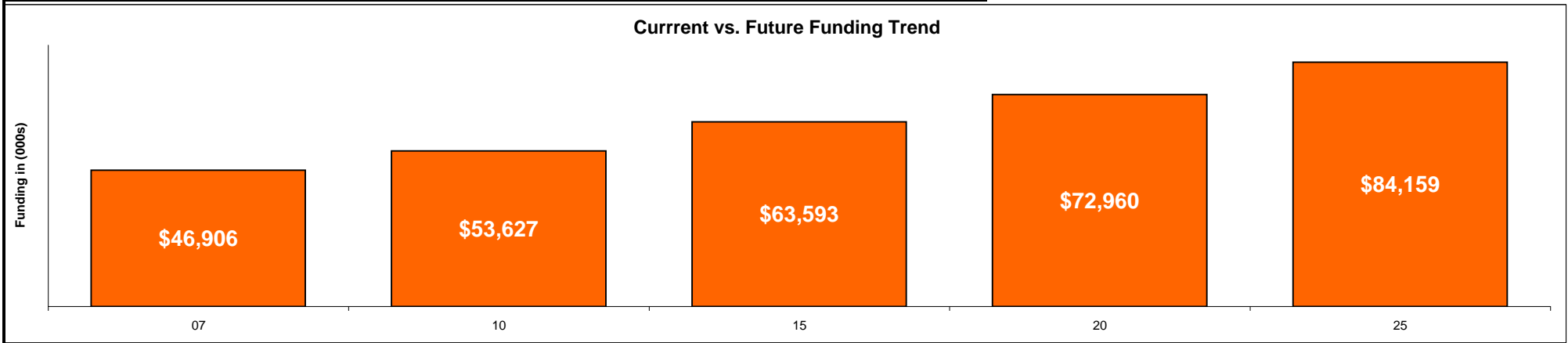
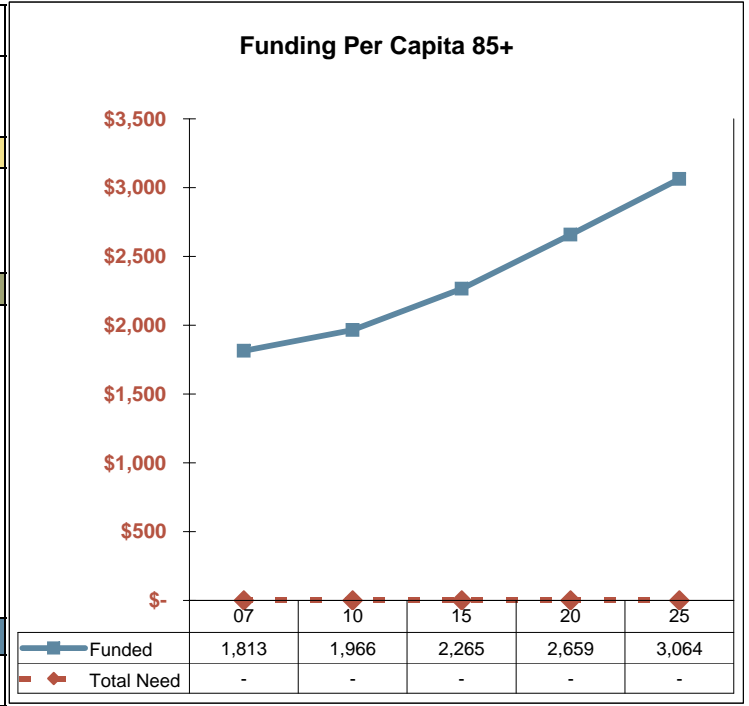



# Licensed Units - ALP/ACF

# FINGER LAKES REGION ESTIMATE

	2010	2015	2020	2025
Base Year 2007	3,969	3,969	3,969	3,969
Adjustment to Regional Use Rate	-	-	-	-
<b>ADJUSTED BASE YEAR</b>	<b>3,969</b>	<b>3,969</b>	<b>3,969</b>	<b>3,969</b>
<b>Cumulative Projected Impact of Population Change</b>				
Net Change in Population	216	337	241	245
<b>Projected Demand (Constant Use Rates)</b> <i>(per Age Cohort)</i>	<b>4,185</b>	<b>4,306</b>	<b>4,210</b>	<b>4,214</b>
<b>Cumulative Projected Impact of Key Demand Influencers</b>				
Net Change in Hospital Use / Transfer Rates	-	-	-	-
Impact of Changes in Wealth/Income (At Risk)	-	-	-	-
Impact of Entitlement Program Funding for Home & Community Alternatives	2	5	8	13
Impact of Changes in Family/Community Caregiving	14	66	108	197
Substitution of Alternative Housing/Service Alternatives for Former NH Residents	140	406	663	957
<b>Projected Impact of Demand Influencers</b>	<b>156</b>	<b>477</b>	<b>779</b>	<b>1,167</b>
<b>PROJECTED DEMAND</b>	<b>4,341</b>	<b>4,783</b>	<b>4,989</b>	<b>5,381</b>
% Change vs. Base Year	9.4%	20.5%	25.7%	35.6%
<i>CAGR % Change during Periods</i>	<i>3.0%</i>	<i>2.0%</i>	<i>0.8%</i>	<i>1.5%</i>

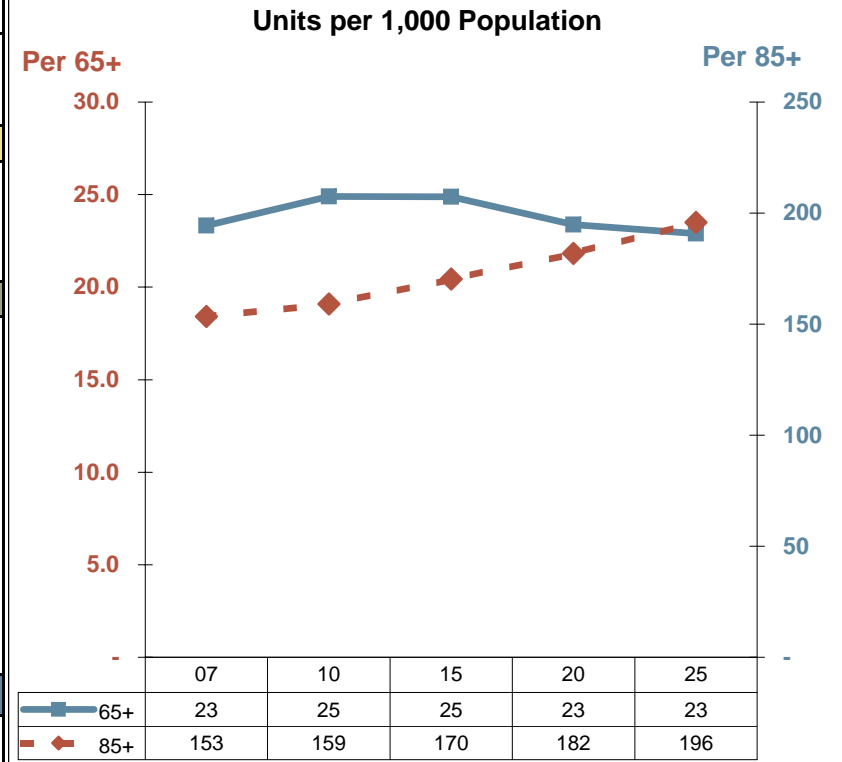

## Current vs. Future Bed Need Trends

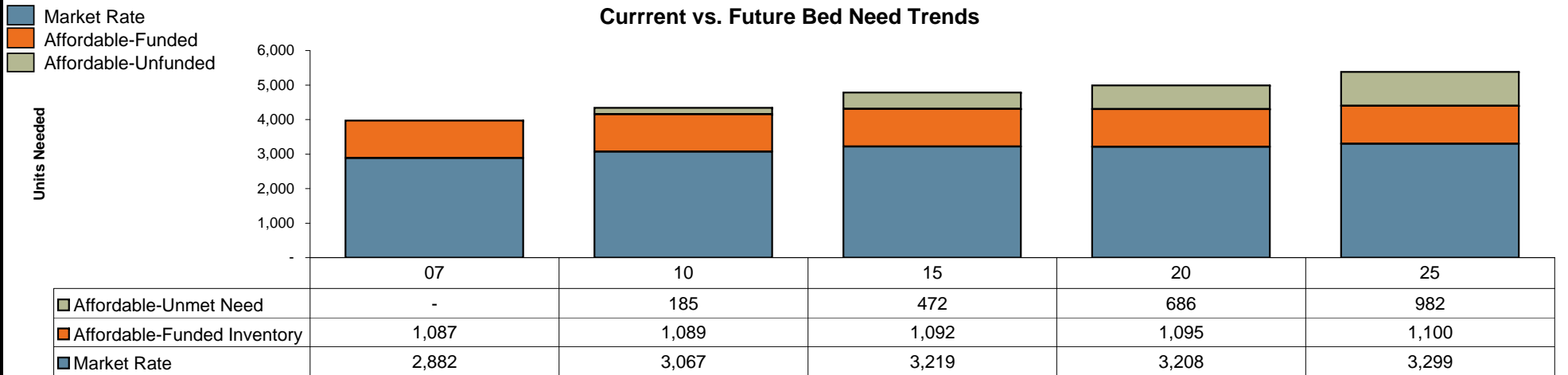

**Unlicensed Housing Funding** **\$ in (000s)** **FINGER LAKES REGION ESTIMATE**

	2010	2015	2020	2025
<b>Base Year 2007</b>	\$ 144,438	\$ 144,438	\$ 144,438	\$ 144,438
<b>Cumulative Projected Impact of Population Change</b>				
Net Change in Population	4,465	8,158	10,791	19,451
<b>Projected Demand (Constant Use Rates)</b> <i>(per Age Cohort)</i>	<b>148,903</b>	<b>152,596</b>	<b>155,229</b>	<b>163,889</b>
<b>Cumulative Projected Impact of Key Demand Influencers</b>				
Net Change in Hospital Use / Transfer Rates	-	-	-	-
Impact of Changes in Wealth/Income (At Risk)	-	-	-	-
Impact of Entitlement Program Funding for Home & Community Alternatives	-	-	-	-
Impact of Changes in Family/Community Caregiving	-	-	-	-
Substitution of Alternative Housing/Service Alternatives for Former NH Residents	2,051	5,937	9,680	13,983
<b>Projected Impact of Demand Influencers</b>	<b>2,051</b>	<b>5,937</b>	<b>9,680</b>	<b>13,983</b>
<b>PROJECTED DEMAND</b>	<b>\$ 150,954</b>	<b>\$ 158,533</b>	<b>\$ 164,909</b>	<b>\$ 177,871</b>
% Change vs. Base Year	4.5%	9.8%	14.2%	23.1%
<i>CAGR % Change during Periods</i>	<i>1.5%</i>	<i>1.0%</i>	<i>0.8%</i>	<i>1.5%</i>

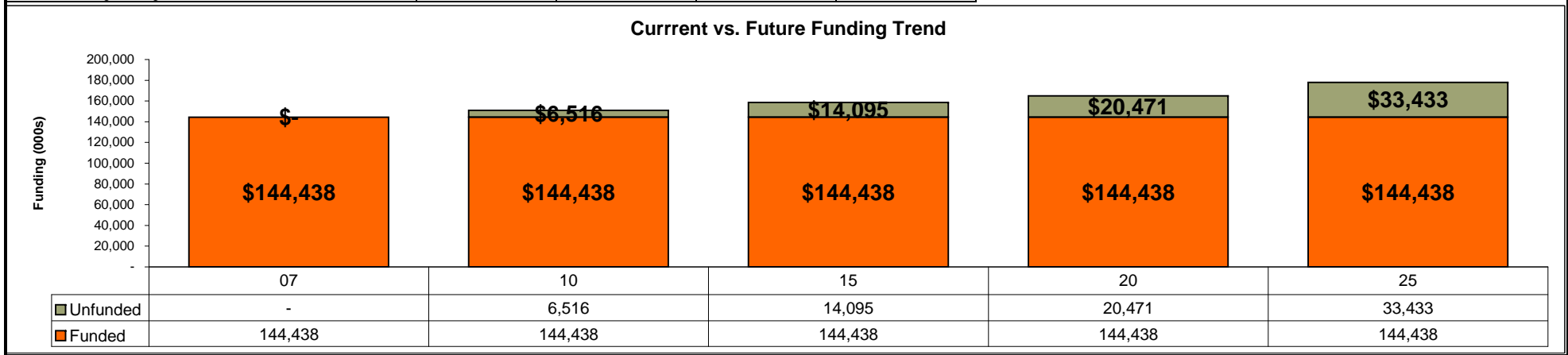
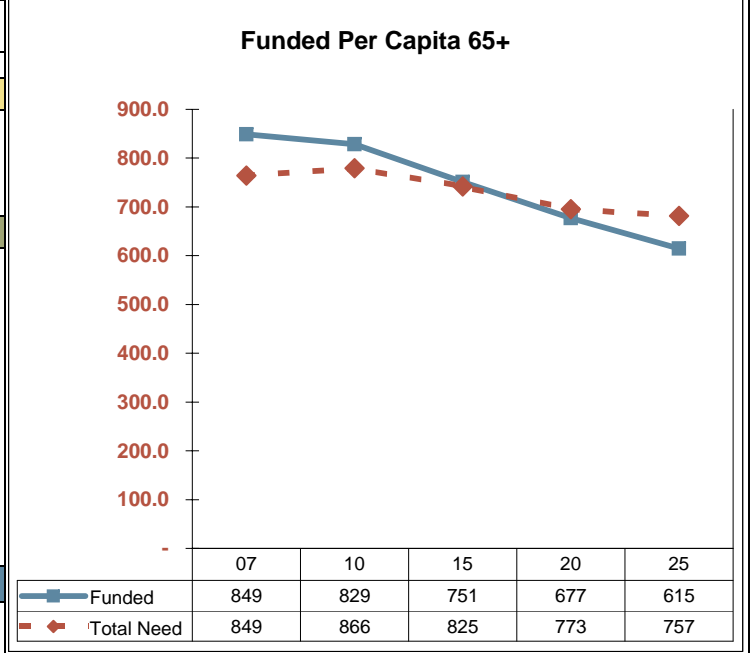

# Unlicensed Units

# FINGER LAKES REGION ESTIMATE

	2010	2015	2020	2025
<b>Base Year 2007</b>	17,500	17,500	17,500	17,500
<b>Cumulative Projected Impact of Population Change</b>				
Net Change in Population	541	988	1,307	2,357
<b>Projected Demand (Constant Use Rates)</b> <i>(per Age Cohort)</i>	<b>18,041</b>	<b>18,488</b>	<b>18,807</b>	<b>19,857</b>
<b>Cumulative Projected Impact of Key Demand Influencers</b>				
Net Change in Hospital Use / Transfer Rates	-	-	-	-
Impact of Changes in Wealth/Income (At Risk)	-	-	-	-
Impact of Entitlement Program Funding for Home & Community Alternatives	-	-	-	-
Impact of Changes in Family/Community Caregiving	-	-	-	-
Substitution of Alternative Housing/Service Alternatives for Former NH Residents	131	378	616	890
<b>Projected Impact of Demand Influencers</b>	<b>131</b>	<b>378</b>	<b>616</b>	<b>890</b>
<b>PROJECTED DEMAND</b>	<b>18,171</b>	<b>18,866</b>	<b>19,423</b>	<b>20,746</b>
% Change vs. Base Year	3.8%	7.8%	11.0%	18.6%
<i>CAGR % Change during Periods</i>	<i>1.3%</i>	<i>0.8%</i>	<i>0.6%</i>	<i>1.3%</i>

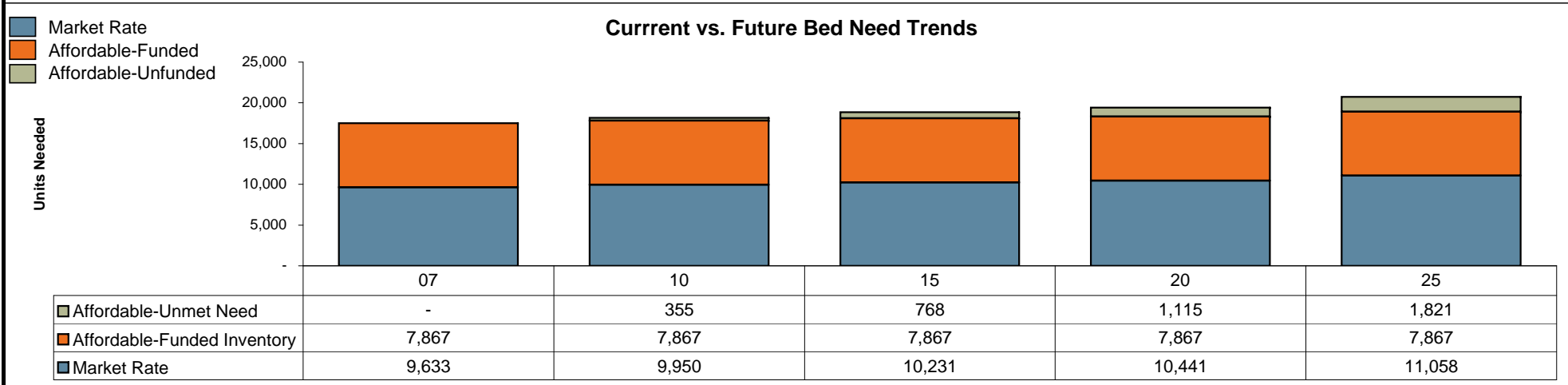
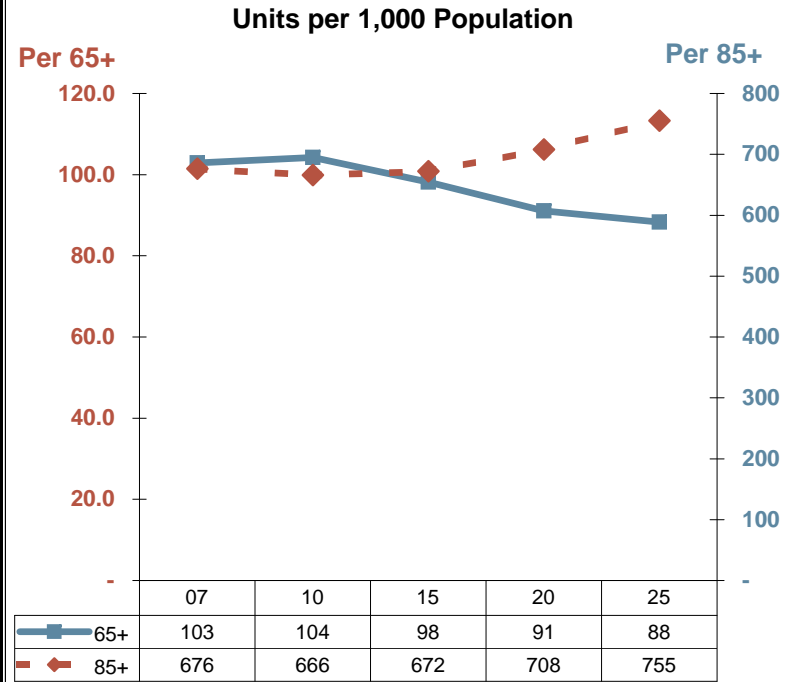

# HOME CARE FUNDING

\$ in (000s)

# FINGER LAKES REGION ESTIMATE

	2010	2015	2020	2025
<b>Baseline</b>	\$ 74,429	\$ 74,429	\$ 74,429	\$ 74,429
<b>Cumulative Projected Impact of Population Change</b>				
Net Change in Population	2,116	9,114	19,431	34,003
<b>Projected Demand (Constant Use Rates) (65+)</b>	<b>76,545</b>	<b>83,543</b>	<b>93,861</b>	<b>108,432</b>
<b>Cumulative Projected Impact of Key Demand Influencers</b>				
Net Change in Hospital Use	-	-	-	-
Impact of Changes in Wealth/Income (At Risk)	-	-	-	-
Impact of Entitlement Program Funding for Home & Community Alternatives	1,011	2,696	4,382	6,067
Impact of Changes in Family/Community Caregiving Substitution of Assisted Living for Former NH Residents	4,311	12,464	23,030	33,259
<b>Projected Impact of Demand Influencers</b>	<b>5,322.4</b>	<b>15,160.2</b>	<b>27,411.9</b>	<b>39,326.1</b>
<b>PROJECTED VISITS</b>	<b>\$ 81,868</b>	<b>\$ 98,703</b>	<b>\$ 121,273</b>	<b>\$ 147,758</b>
% Change vs. Base Year	10.0%	32.6%	62.9%	98.5%
CAGR % Change vs. Base Year	3.2%	3.6%	3.8%	3.9%

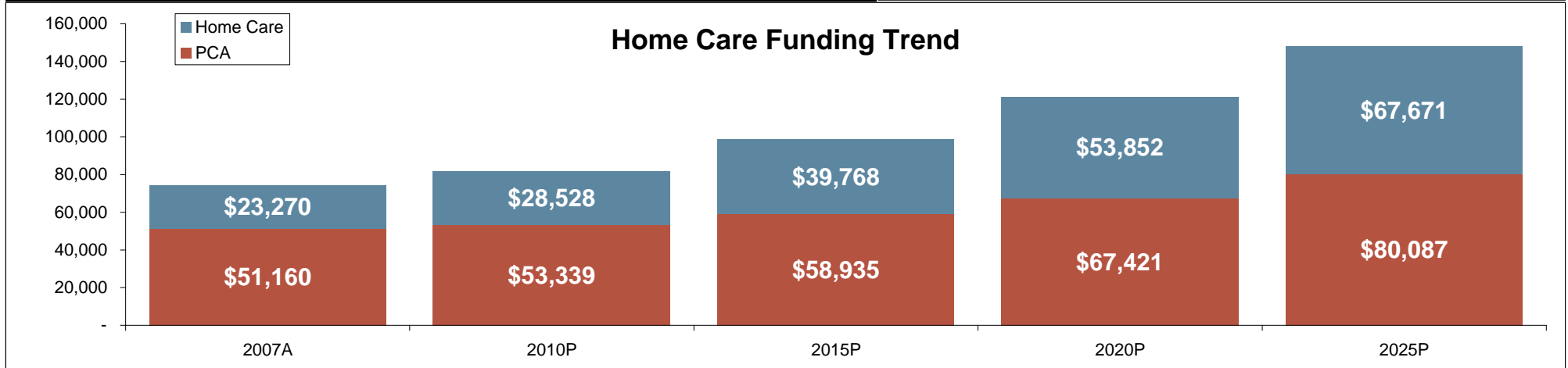
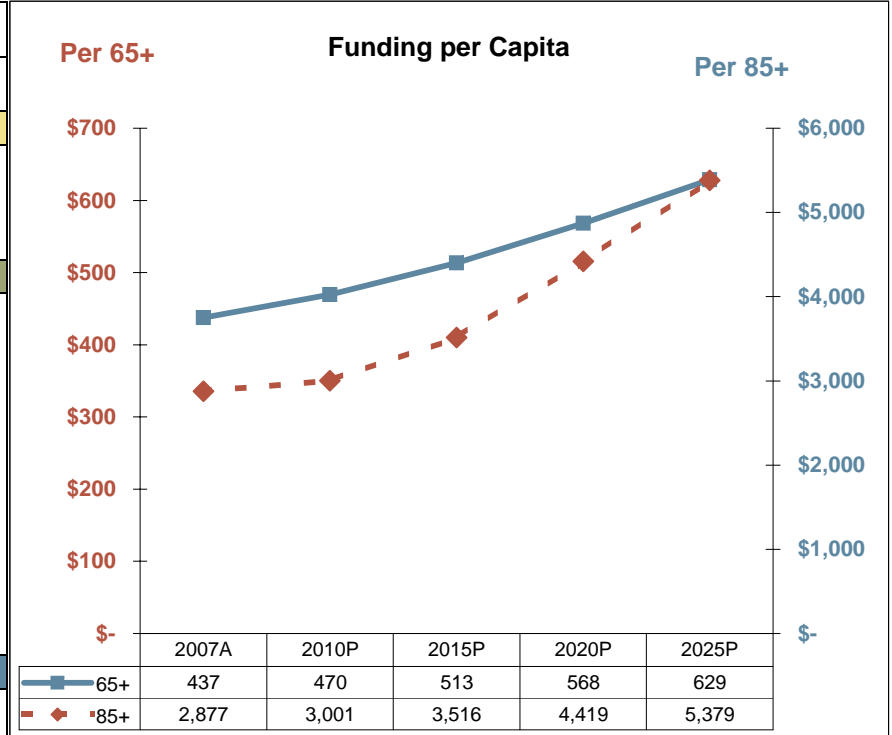

# HOME CARE VISITS

# FINGER LAKES REGION ESTIMATE

(in Thousands of Visits)	2010	2015	2020	2025
<b>Baseline</b>	3,323.8	3,323.8	3,323.8	3,323.8
<b>Cumulative Projected Impact of Population Change</b>				
Net Change in Population	57.4	245.6	520.6	902.3
<b>Projected Demand (Constant Use Rates) (65+)</b>	<b>3,381.2</b>	<b>3,569.4</b>	<b>3,844.4</b>	<b>4,226.1</b>
<b>Cumulative Projected Impact of Key Demand Influencers</b>				
Net Change in Hospital Use	-	-	-	-
Impact of Changes in Wealth/Income (At Risk)	-	-	-	-
Impact of Entitlement Program Funding for Home & Community Alternatives	24.6	65.6	106.7	147.7
Impact of Changes in Family/Community Caregiving	-	-	-	-
Substitution of Assisted Living for Former NH Residents	81.3	235.2	383.4	553.7
<b>Projected Impact of Demand Influencers</b>	<b>106.0</b>	<b>300.8</b>	<b>490.1</b>	<b>701.4</b>
<b>PROJECTED VISITS</b>	<b>3,487.1</b>	<b>3,870.3</b>	<b>4,334.5</b>	<b>4,927.5</b>
% Change vs. Base Year	4.9%	16.4%	30.4%	48.2%
CAGR % Change vs. Base Year	1.6%	1.9%	2.1%	2.2%

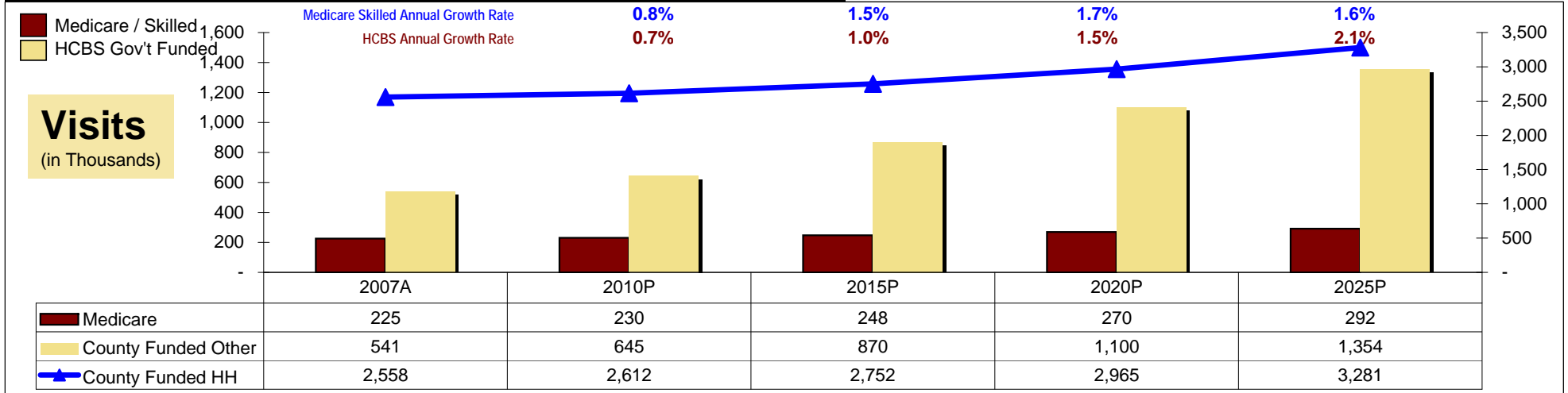
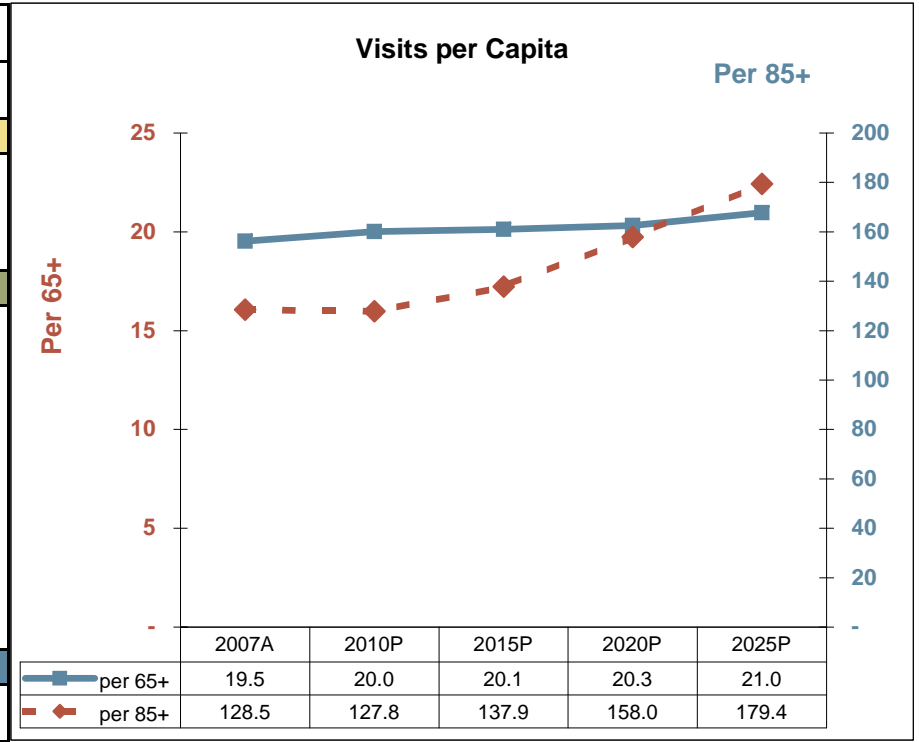

# ADULT DAY CARE FUNDING

\$ in (000s)

# FINGER LAKES REGION ESTIMATE

	2010	2015	2020	2025
<b>Baseline</b>	\$ 790	\$ 790	\$ 790	\$ 790
<b>Cumulative Projected Impact of Population Change</b>				
Net Change in Population	-	83	205	319
<b>Projected Demand (Constant Use Rates) (65+)</b>	<b>790</b>	<b>873</b>	<b>995</b>	<b>1,109</b>
<b>Cumulative Projected Impact of Key Demand Influencers</b>				
Net Change in Hospital Use	-	-	-	-
Impact of Changes in Wealth/Income (At Risk)	-	-	-	-
Impact of Entitlement Program	-	-	-	-
Funding for Home & Community Alternatives	-	-	-	-
Impact of Changes in Family/Community Caregiving	-	-	-	-
Substitution of Assisted Living for Former NH Residents	477	1,381	2,553	3,687
<b>Projected Impact of Demand Influencers</b>	<b>477</b>	<b>1,381</b>	<b>2,553</b>	<b>3,687</b>
<b>PROJECTED VISITS</b>	<b>\$ 1,267</b>	<b>\$ 2,255</b>	<b>\$ 3,548</b>	<b>\$ 4,796</b>
% Change vs. Base Year	60.4%	185.5%	349.2%	507.3%
<i>CAGR % Change vs. Base Year</i>	<i>17.1%</i>	<i>14.0%</i>	<i>12.3%</i>	<i>10.5%</i>

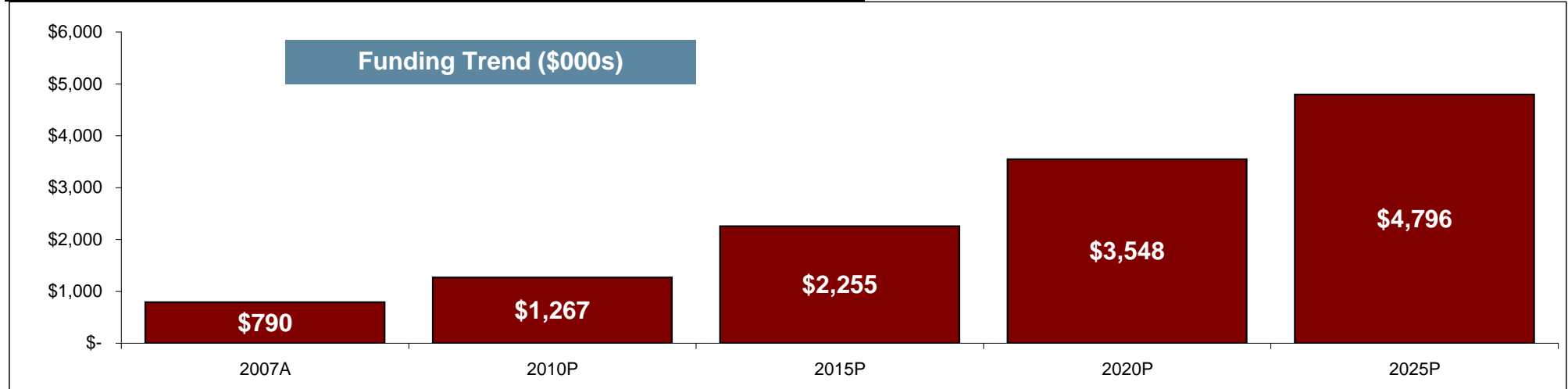
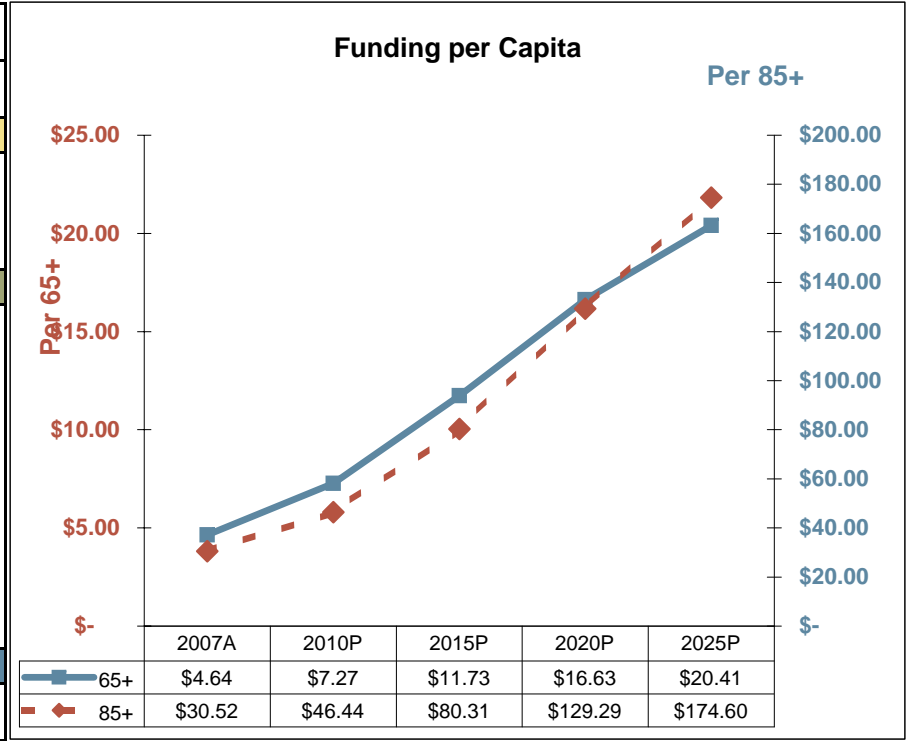

# ADULT DAY CARE

# FINGER LAKES REGION ESTIMATE

(Visits/Days)	2010	2015	2020	2025
<b>Baseline</b>	58,109	58,109	58,109	58,109
<b>Cumulative Projected Impact of Population Change</b>				
Net Change in Population	-	5,986	13,019	20,229
<b>Projected Demand (Constant Use Rates) (65+)</b>	<b>58,109</b>	<b>64,095</b>	<b>71,127</b>	<b>78,338</b>
<b>Cumulative Projected Impact of Key Demand Influencers</b>				
Net Change in Hospital Use	-	-	-	-
Impact of Changes in Wealth/Income (At Risk)	-	-	-	-
Impact of Entitlement Program Funding for Home & Community Alternatives	-	-	-	-
Impact of Changes in Family/Community Caregiving	-	-	-	-
Substitution of Assisted Living for Former NH Residents	5,353	15,494	25,262	36,490
<b>Projected Impact of Demand Influencers</b>	<b>5,353</b>	<b>15,494</b>	<b>25,262</b>	<b>36,490</b>
<b>PROJECTED VISITS</b>	<b>63,462</b>	<b>79,589</b>	<b>96,390</b>	<b>114,829</b>
% Change vs. Base Year	9.2%	37.0%	65.9%	97.6%
CAGR % Change vs. Base Year	3.0%	4.0%	4.0%	3.9%

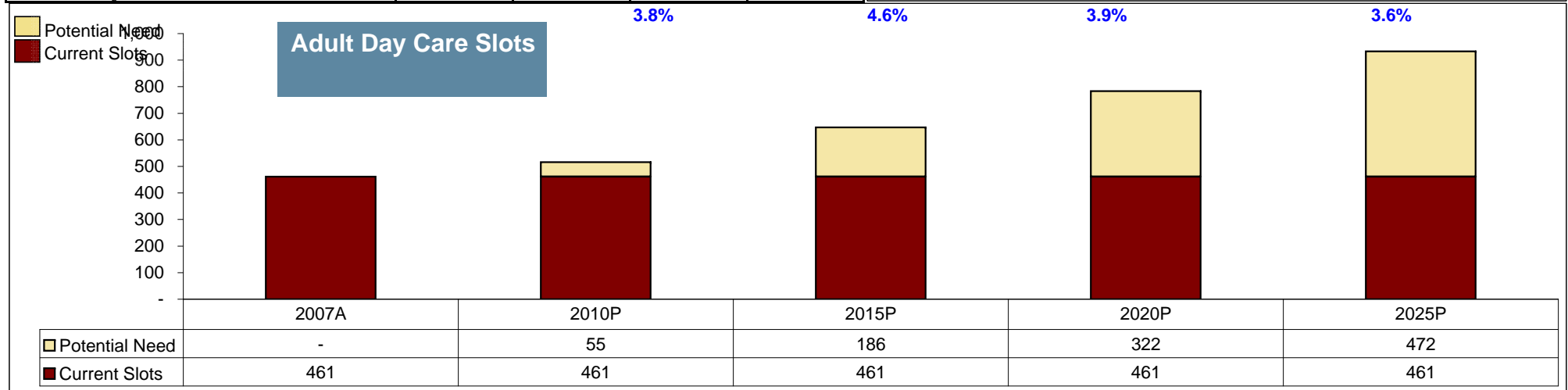
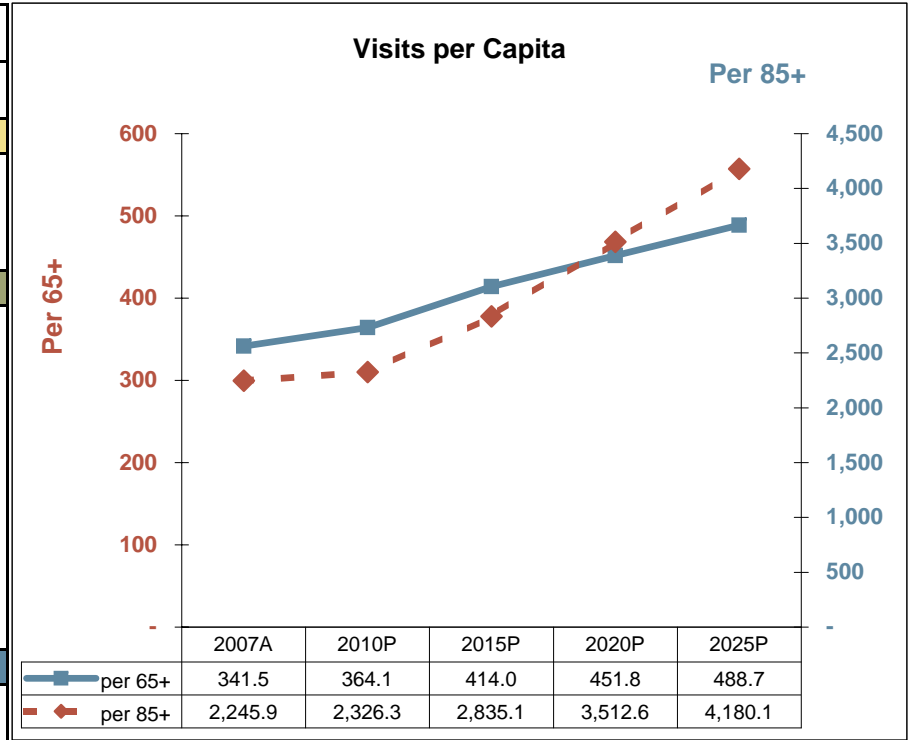

SENIOR CARE WORKFORCE PROJECTIONS

Estimated 2007 through Projected 2025

FINGER LAKES REGION ESTIMATE

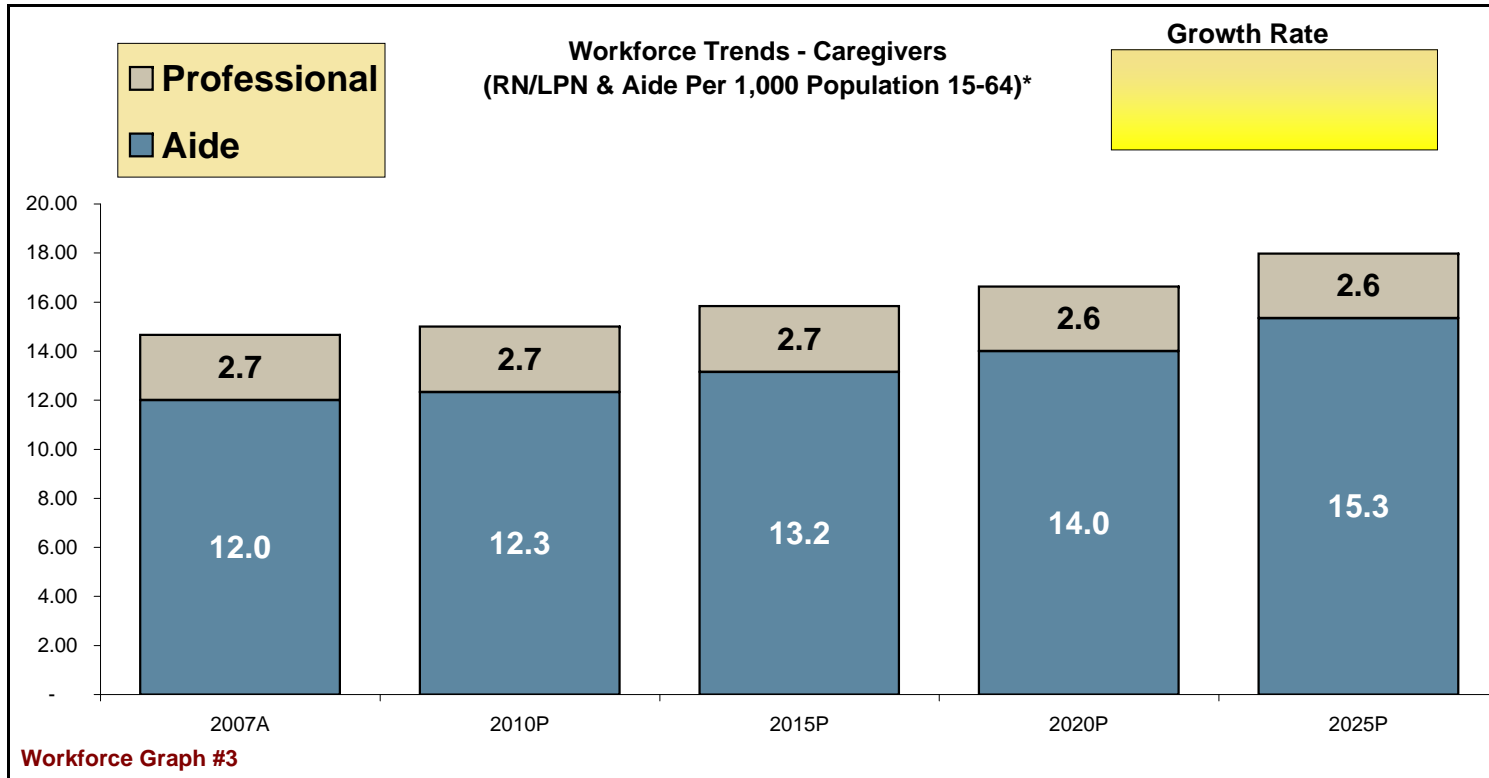

Estimated FTEs* (in Thousands)					
	2007A	2010P	2015P	2020P	2025P
<b>Aide</b>	10,162	10,479	10,924	11,247	11,863
<b>RN/LPN</b>	2,252	2,272	2,231	2,118	2,037

\*Estimated FTE's need for SNF, Assisted Living and Home Care

\*\*Compound Annual Growth Rate (CAGR) - FTE's



SENIOR CARE WORKFORCE PROJECTIONS

Estimated 2007 through Projected 2025

FINGER LAKES REGION ESTIMATE

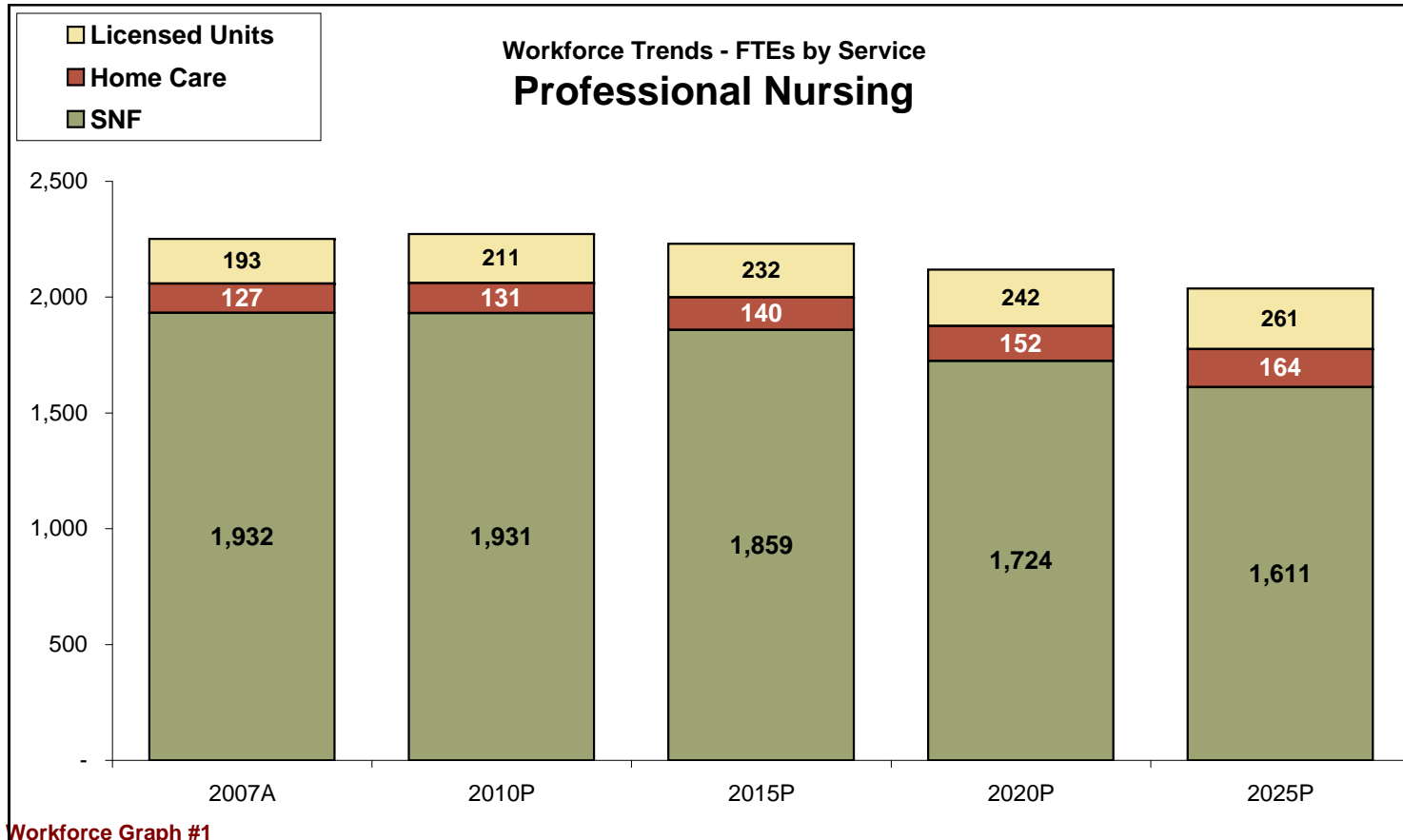

Workforce Graph #1

Estimated FTEs* (in Thousands)					
	2007A	2010P	2015P	2020P	2025P
<b>RN/LPN</b>	2,252	2,272	2,231	2,118	2,037

\*Estimated FTE's need for SNF and Home Care



Estimated 2007 through Projected 2025

**FINGER LAKES REGION ESTIMATE**

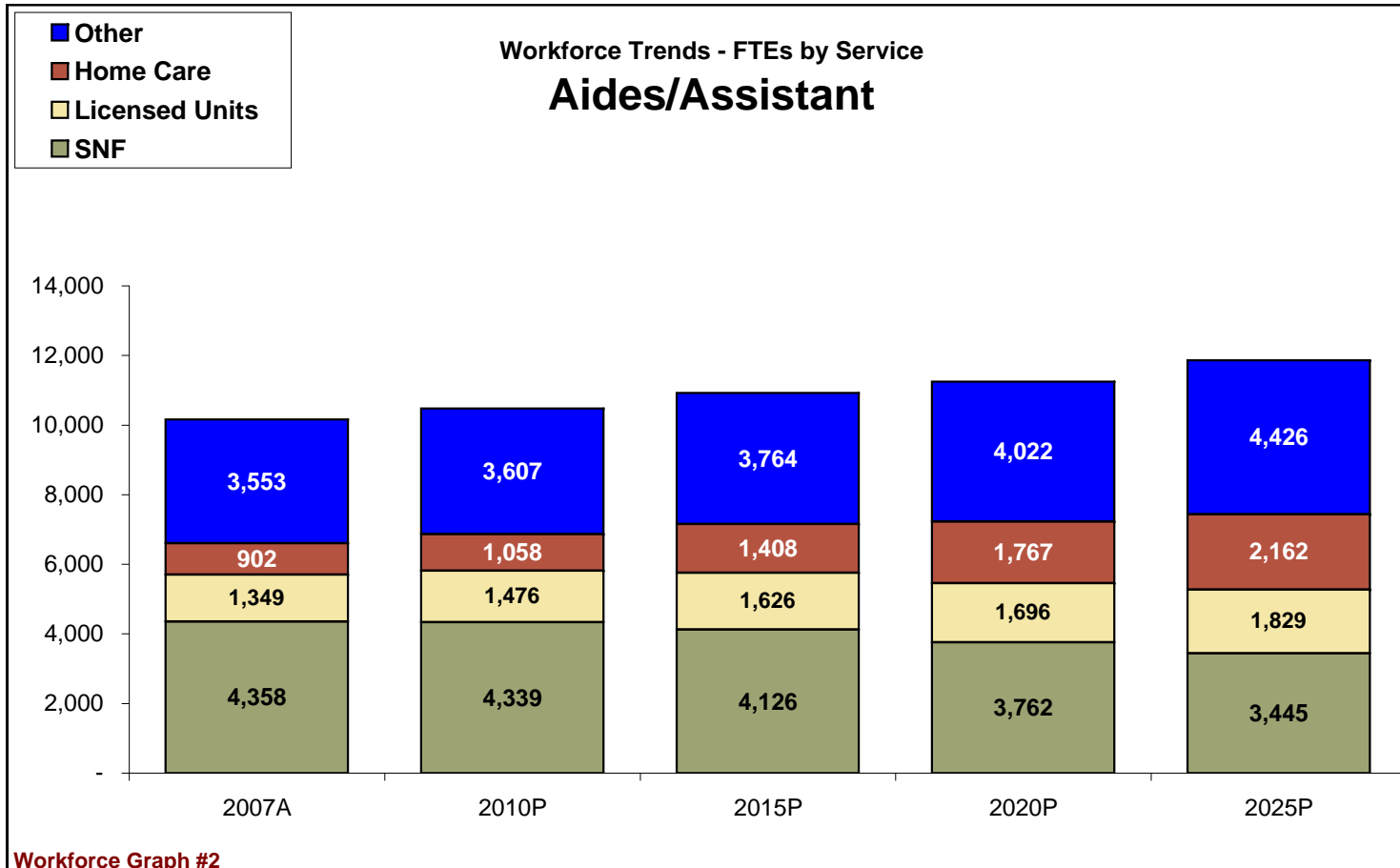

Workforce Graph #2

Estimated FTEs* (in Thousands)					
	2007A	2010P	2015P	2020P	2025P
<b>Aides</b>	10,162	10,479	10,924	11,247	11,863

\*Estimated FTE's need for SNF, Assisted Living and Home Care

# WORKFORCE STAFFING ASSUMPTIONS

## Nursing Home

### INPUT Total Paid Hours per Day

#### Short Stay

Professional	2.00
Aide	2.50
TOTAL	4.50

#### Moderate / Long Stay

Professional	1.00
Aide	2.50
TOTAL	3.50
Productivity Factor	86.5%

## Assisted Living

### INPUT Total Paid Hours per Day

#### Market Rate & Subsidized

Professional	0.25
Aide	1.75
TOTAL	2.00
Productivity Factor	86.5%

### INPUT Total Paid Hours per Visit

#### Medicare / Skilled

Professional	1.60	5.0 Visits / Day
Aide / PCA	1.45	5.5 Visits / Day

#### Other Home Care Services

Professional	0.50	
Aide / PCA	2.50	Hours Per Visit
Productivity Factor	86.5%	

## FINGER LAKES REGION ESTIMATE

		2007E	2010P	2015P	2020P	2025P
<b>CURRENT &amp; PROJECTED POPULATION</b>						
Age 15-64		846,699	849,941	830,538	803,606	773,004
Females Age 45 - 64	B	170,720	177,893	175,827	165,625	153,100
Age 65+		170,143	174,300	192,255	213,350	234,979
Age 65-74		84,703	89,882	108,712	124,201	132,930
Age 75-84		59,567	57,138	55,470	61,708	74,579
Age 65-84		144,270	147,020	164,182	185,909	207,509
Age 85+	A	25,874	27,280	28,073	27,441	27,470
<b>LIVING ALONE AND CAREGIVER RATIOS</b>						
Caregiver Ratio	B / A	6.6 to 1	6.5 to 1	6.3 to 1	6.0 to 1	5.6 to 1
<b>PROJECTED GROWTH RATES vs. 2007</b>						
Age 15-64			0.4%	-1.9%	-5.1%	-8.7%
Females Age 45 - 64			4.2%	3.0%	-3.0%	-10.3%
Age 65+			2.4%	13.0%	25.4%	38.1%
Age 65-74			6.1%	28.3%	46.6%	56.9%
Age 75-84			-4.1%	-6.9%	3.6%	25.2%
Age 65-84			1.9%	13.8%	28.9%	43.8%
Age 85+			5.4%	8.5%	6.1%	6.2%
Caregiver Ratio			-1.2%	-5.1%	-8.5%	-15.5%